



2340 South 900 West

Salt Lake City, UT 84119

801-974-9116 Fax: 801-974-5458

# **PUTT FORE PRIZES**

## **OPERATING INSTRUCTIONS**

**\* GAME MUST BE LEVEL TO  
OPERATE PROPERLY**

## **DESCRIPTION**

Putt Fore Prizes is an interactive skill game with instant prize redemption. It incorporates a three-tiered prize system consisting, of a small prize, medium prize and large prize.

## **GAME OBJECTIVE**

The object of the game is to score as many points as possible by using players' skill to putt the play ball into the various cups on the green. Each cup is labeled with the points that are scored for that hole.

## **GAME FEATURES**

- , Addictive game play
- , True skill game
- , Suitable for all ages
- , Sound effects and music track
- , Three prize levels, small, medium and large
- , Winner Every Time
- , Attractive graphics
- , Custom logos available

## **MACHINE FEATURES**

- C Heavy duty construction
- C Mars bill acceptor, stacker.
- C Total vend counter
- C Volume control
- C Rope light controllers
- C Locking caster wheels
- C Cabinet levelers
- C Display shelf for small, medium, and large prize
- C Dispenses a variety of Small Prizes:
  1. 27mm or 32mm super balls
  2. 850 or 600 count gumballs
  3. 850 or 600 count jawbreakers
  4. 1040 count Sweet Revenge
  5. 700 count Megabytes
  6. 1 to 1¼" round capsules
- C Dispenses a variety of Medium Prizes:
  1. 45mm super balls
  2. 49mm super balls
  3. 2" standard or round capsules
- C Dispenses a 3¾ to 4" (95mm to 100mm) capsule for the large prize
- C Small Prize capacity: 2,000 1" product
- C Medium Prize capacity: 200 2" capsules or 45/49mm super balls
- C Large Prize capacity: 42 4" (100mm) capsules
- C 220 volt option available
- C Coin acceptors for tokens or foreign coins available
- C Credits and remaining balls display
- C Game default set for 50 cent vend; can be set for 1 to 4 coins
- C Adjustable balls per play
- C Adjustable point values for small, medium and large prize
- C Winner every play
- C Small, medium & large prize counters to easily determine product cost and net profit

## OPERATING INSTRUCTIONS

1. Located in the coin cash box are:
  - C Extra fuse
  - C Velcro
  - C Spanner security bit (snake eye) and putter handle security bit
  - C Instructions and decals for bill and coin acceptors
  - C Menu Options are located on inside cabinet wall of coin cash box
2. Load small prize, medium prize and large prize products in the rear of unit by removing upper back door (see figure 1). Load small prize product by dumping product into the small prize hopper (see figure 1-A). Load medium prize product by dumping product into the medium prize hopper (see figure 1-B). Load large prize capsules one at a time starting with the lowest row, working up to top row (see figure 1-C).
3. With the upper back door off, now place your small, medium and large prize display pieces in the appropriately marked display compartments (see figure 2). After all product is filled and display prizes are set, replace upper back door.
4. Remove front shield by first removing the putter handle security screw and then the two spanner screws on each side of the machine (see figure 3A-3C). Test small, medium, and large prize dispensers by starting play with bill or coins and drop the play ball through the point holes to obtain the appropriate score to test the small, medium and large prize dispensing mechanisms.
5. With front shield off, place the bubble level on the bull's eye flat spot of the play field (see figure 4A & 4B). Adjust the level of the machine using the four levelers under the corners of the cabinet. Factory default point settings are based on unit being level. **Changing the level of the machine affects the difficulty of play**, e.g., tilting the unit backwards makes it more difficult to get the ball into the 1,000-point hole. Lowering the front makes it easier to get into the 1,000-point hole. Setting the right side lower makes it more difficult and easier with the left side being lower. It is critical to properly adjust the level of the machine and adjust the point's settings for the ability of the players at each specific location. Remember your payout is controlled by the point values set for each prize.
6. Degree of difficulty can also be changed by adjusting the spring tension setting on the putter (see figure 4C). There are four holes for adjustment on the tension with hole #1 being at the top and hole #4 at the bottom. Default setting is hole #2. Setting the tension to hole #1 makes the game more easy and setting the tension to hole #3 or increases the difficulty.
7. Replace front shield and secure with the spanner screws provided. Replace putter handle with security screw.
8. The circuit board is located through the lower back door (see figure 5). This door provides service access to the board and its components, rope light controllers, volume control, prize delivery chute, prize flap, small and medium prize motors.
9. Total vend counter is mounted and viewable through the coin door and can be easily seen when door is fully opened (see figure 6).
10. Menu Options are located on the left wall inside coin door as well as on the next page (see figure 6A). Red and yellow menu buttons are located next to the counter (see figure 6B).
11. For technical service and trouble shooting please call our **Putt Fore Prizes** technical service representative at 1-801-974-9116.

## PUTT FORE PRIZES MENU OPTIONS

Menu options are shown on the credit display. The left display (score) shows the settings and the right display (balls remaining) shows the menu option number. The menu option buttons are located behind the coin door. The red button will cycle through the thirteen menu options advancing to the next option each time it is pressed. The yellow button will cycle through the available settings for the selected menu option. Pressing the yellow button on options 11,12 & 13 (the small, medium, and large prize counters) will reset the count to zero. Return to game play by pressing the red button after option 15 to reset the display to show 0 credits and 0 remaining balls.

1. **Balls per credit** (number of balls per each game credit)  
Can be from one to nine balls per credit (**default: 7**)
2. **Coins per credit** (number of coins for one credit)  
1 = 1  
2 = 2 (**default**)  
3 = 3  
4 = 4
3. **Number of games per credit (default: 1 game per credit)** Can be set from one to four.
4. **1,000 point hole option (Highly recommended to leave at default setting)**
  1. Instant large prize winner (Does not end game, next ball will score points or win another large prize. Game is over after seventh ball is played)
  2. Instant medium prize winner (Does not end game, next ball will score points or win another medium prize. Game is over after seventh ball is played)
  3. 1,000 points (**default**)
  4. Rotate 1 through 3
5. **Winner Every Time** (dispenses a Small Prize with every play)\*  
**\*This feature is currently disabled. Set small prize value at 700 points (default) which makes game a winner every time. Raise small prize value to 800 points or greater to make game a non winner every time.**  
  
0 = Off (**default**)  
1 = On
6. **NOT AVAILABLE**  
0 = On  
1 = Off (**default**)
7. **Music tracks**  
0 = Same song plays all through game (**default**)  
1 = Sound effects rotate through the game
8. **Small prize win point level (default: 700)**
9. **Medium prize win point level (default: 3,800)**
10. **Large prize win point level (default: 5,400)**

- 11. **Small Prize Count** Displays the number of Small Prizes dispensed
- 12. **Medium Prize Count** Displays the number of Medium Prizes dispensed
- 13. **Large Prize Count** Displays the number of Large Prizes dispensed
- 14. **30 second play ball delivery** (delivers a play ball if no points are scored after 30 seconds from previous ball delivery)  
 0 = Off (**default**)  
 1 = On
- 15. **Prize Dump switch** Enables operator to unload/dump prizes by activating the prize motors.
  - 1. Small Prize
  - 2. Medium Prize
  - 3. Large Prize
- 16. **Return display to 0 0 for game operation**

### OPERATING SUGGESTIONS

The game default settings are arbitrarily set by OK MFG based upon our testing. These may or may not meet the needs of your locations. Factors that should be considered in determining game settings are location, customer age, customer skill level and value of medium and large prizes. Default settings are for younger player and may need to be set higher as game skill dictates.

Critical games settings:

- C Number of balls per play (default: 7). This can be set from one to nine balls per play. The number of balls per play does affect the length of game play.
- C Number of coins per credit (default: 2, 50¢). This can be set from one to four coins.
- C Number of games per credit (default: 1). This can be set from one to four credits.
- C Small prize point value (default: 700). This can be set from 300 to 2,100 points. Every ball scores; therefore, setting the small prize point value at the lowest possible score based upon the number of plays balls (default: 7 balls x 100 pts. = 700 points) makes the game a “**Winner Every Time**”. This means that a prize is won with every game play. Setting the point value 100 points above the lowest possible points, e.g. 800 requires a player to now score 800 points to receive a small prize and no prize will dispense for a score of 700 points.
- C Medium prize point value (default: 3,800). This can be set from 600 to 7,100 points.
- C Large prize point value (default: 5,400). This can be set from 1,200 to 7,100 points.

### OPERATING TIPS

- C Maintaining desirable merchandise that has a high perceived value such as licensed products and rotation of product will produce higher revenues.
- C Maintain a display of prizes that is attractive. Remember to update display when changing or rotating product.
- C Control product cost and pay out by adjusting the prize points values. A skill game that is challenging with prize scores that are attainable will help to establish a game that everyone will want to play and play again.



FIGURE 1A, 1B, 1C



FIGURE 2

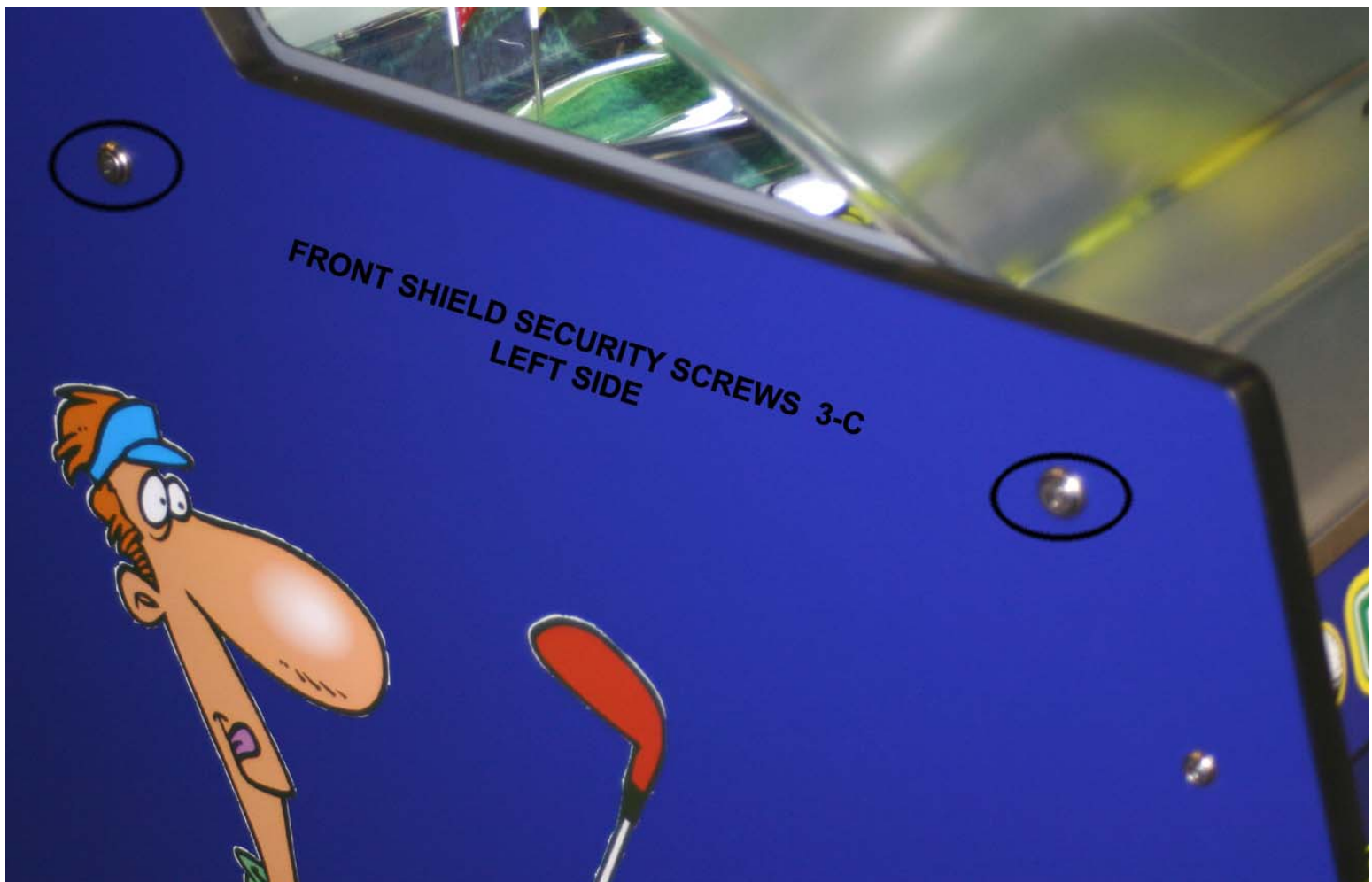
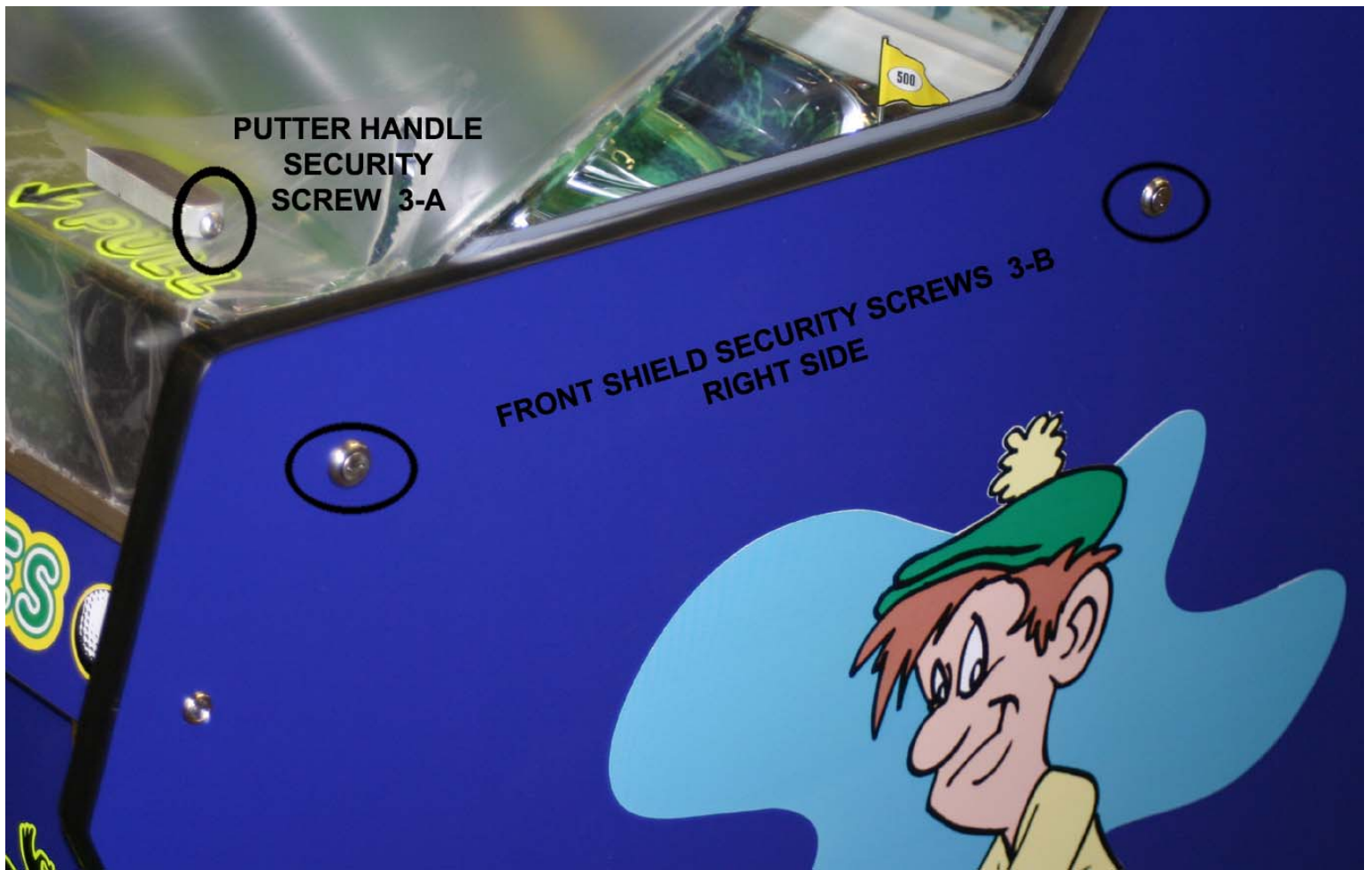
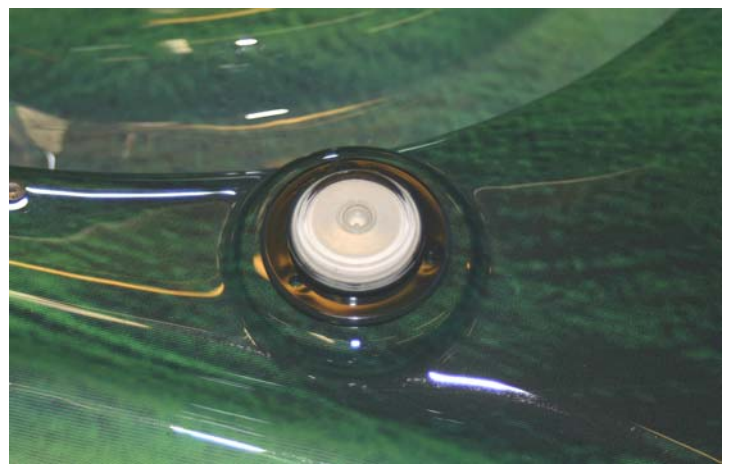

FIGURE 3A, 3B, 3C



**FIGURE 4A**



**FIGURE 4B**

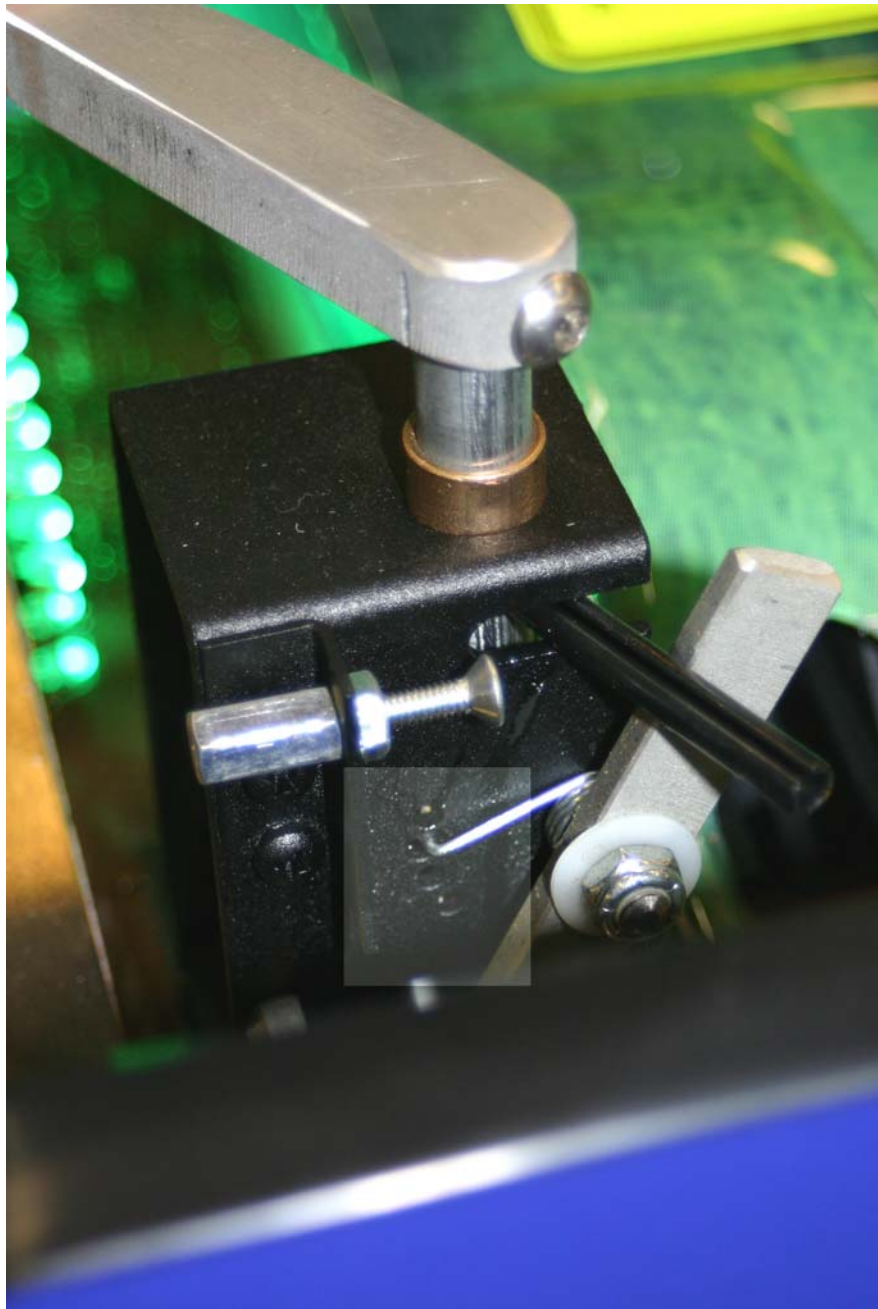

**FIGURE 4C**

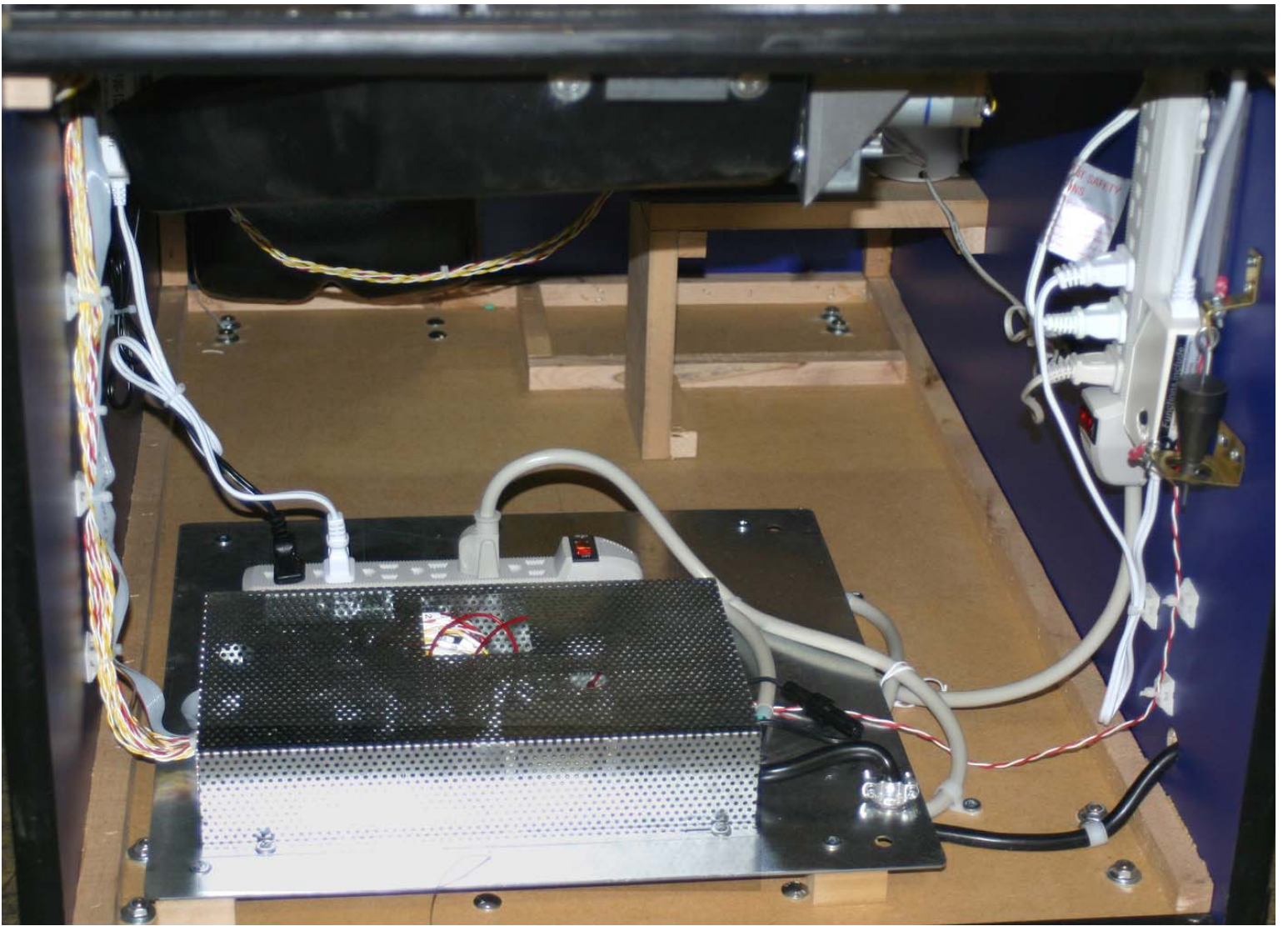

**FIGURE 5**

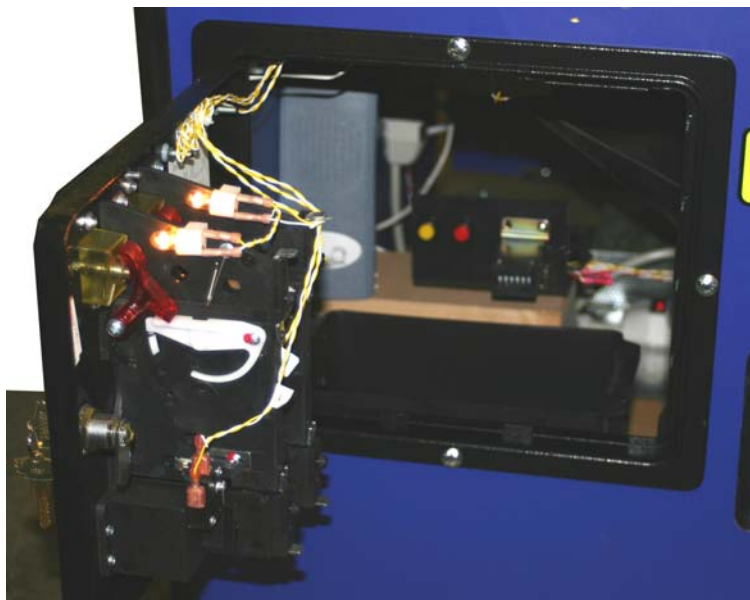

FIGURE 6

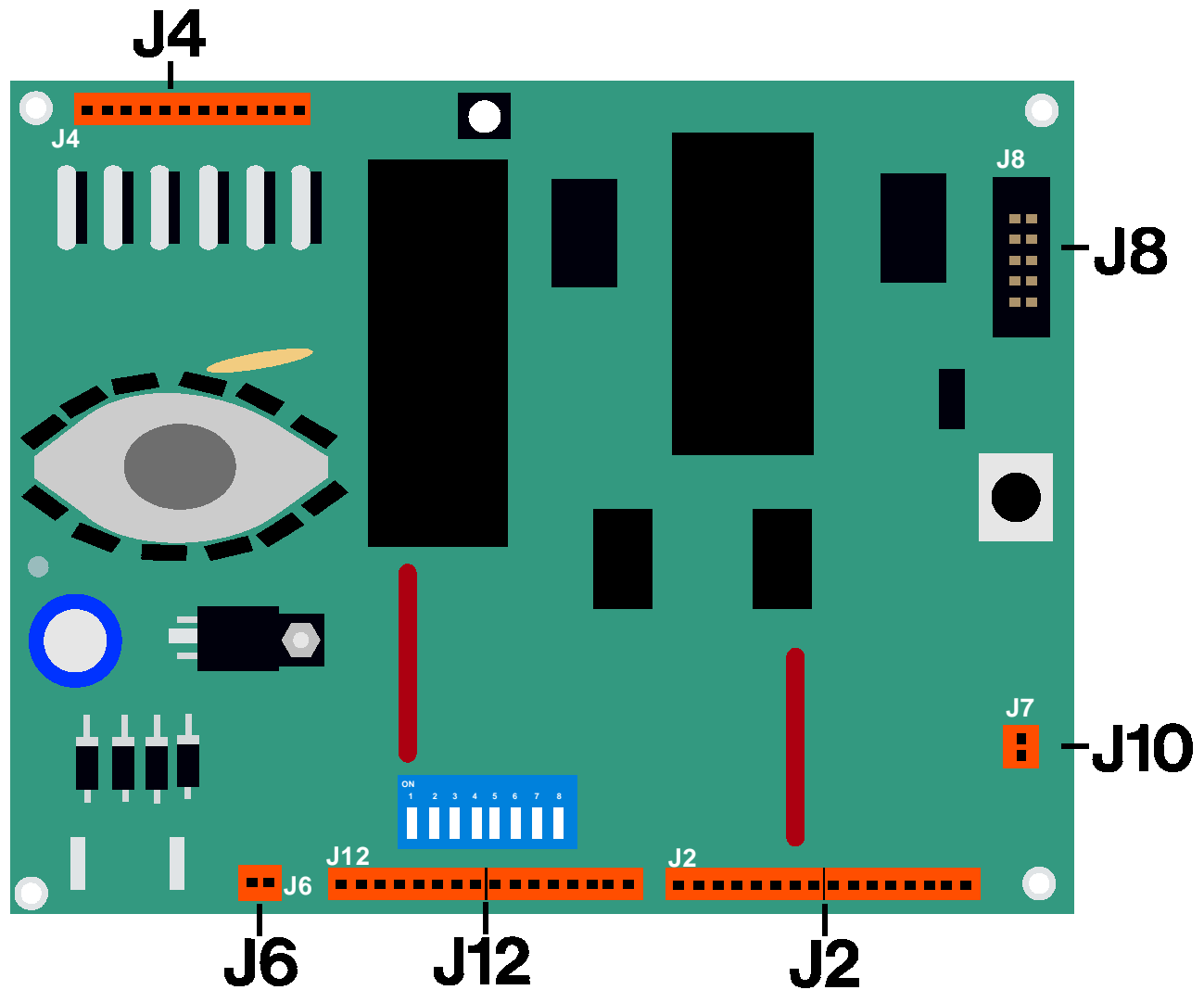

FIGURE 6A



FIGURE 6B

# Circuit Board



## J2 (left to right)

1. Coin Acceptor
2. Token or dual coin acceptor
3. 1,000 point switch
4. 500 point switch
5. Not Used
6. Not Used
7. 200 point switch
8. 100 point switch

## J12 12 Volt Inputs (left to right)

9. Large prize switch
10. Medium prize switch
11. Ball feed stop switch
12. Small prize switch
13. Not Used
14. Bill acceptor
15. Display, Menu Button #1-Yellow
16. Display, Menu Button #2-Red

## J4 12 Volt Outputs (left to right)

17. Green LED, wire #26
18. Coin reject light, wire #25
19. Ball feed motor
20. Small prize motor
21. Medium prize motor
22. Large prize motor

## J6

23. Total vend counter

## J7

24. Speaker Out

## J8

Display

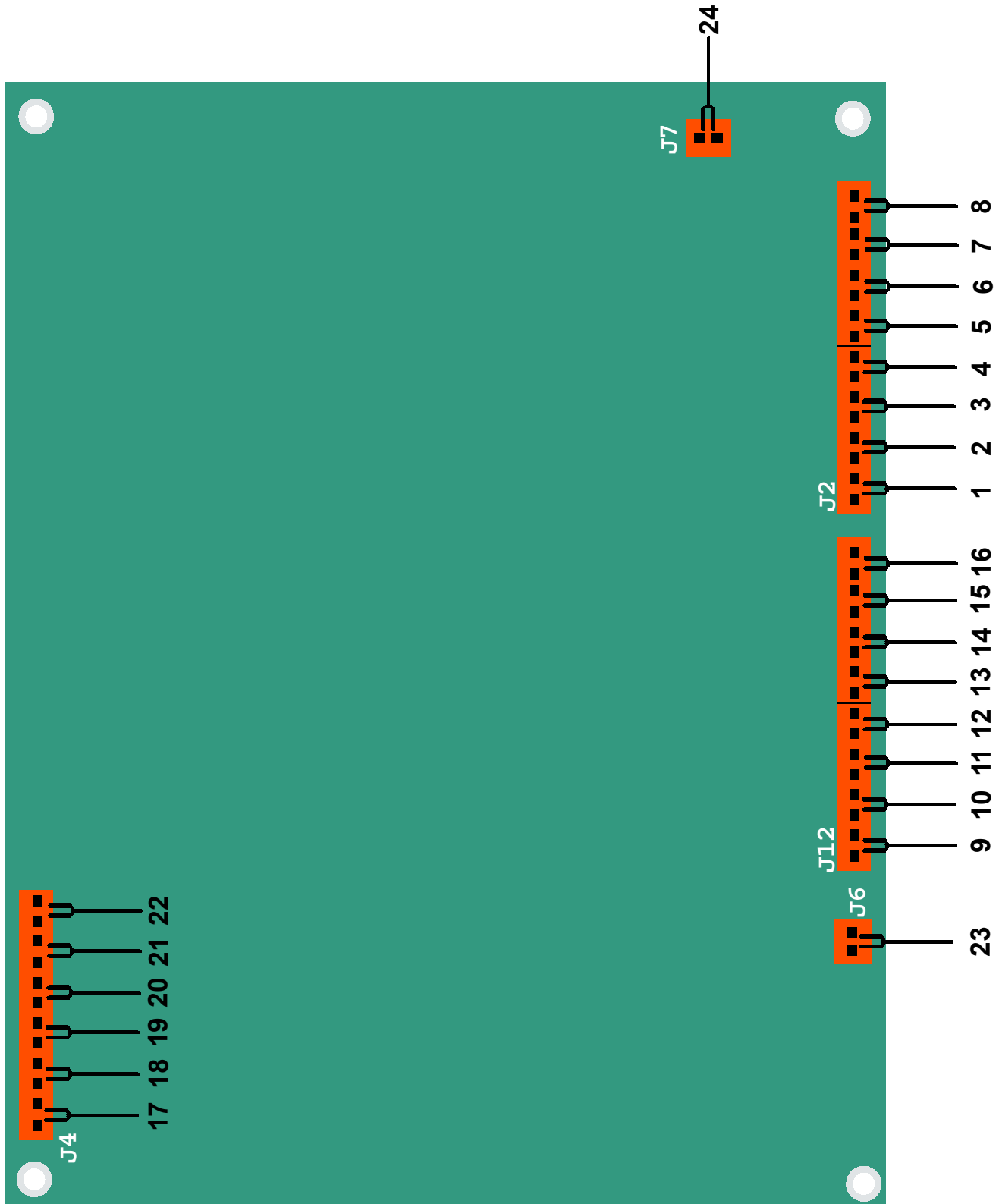

**J2 Wire #**

- 1. Coin acceptor
- 2. Token or dual coin acceptor
- 3. 1,000 point switch
- 4. 500 point switch
- 5. Not Used
- 6. Not Used
- 7. 200 point switch
- 8. 100 point switch

**J12 Wire #**

- 9. Large prize switch
- 10. Medium prize switch
- 11. Ball feed stop switch
- 12. Small prize switch
- 13. Not Used
- 14. Bill acceptor
- 15. Display, menu button, yellow
- 16. Display, menu button, red

**J4 Wire #**

- 17. Green LED light, wire #26
- 18. Coin reject light, wire #25
- 19. Ball feed motor
- 20. Small prize motor
- 21. Medium prize motor
- 22. Large prize motor
- J6--23. Total vend counter
- J7--24. Speaker out
- J8--Dispay

Small, medium and large prizes are available from OK Manufacturing. To view samples of our products, visit our web site at [www.okmfg.net](http://www.okmfg.net)  
Call 1-800-748-5480 to order.